

GRACO®

Stroller

OWNER'S MANUAL

Model No. _____
Serial No. _____

Dear Customer,
Please fill in the model and serial numbers above from the label on the rear leg of your new stroller.

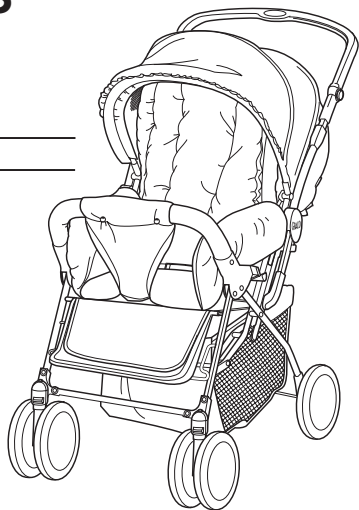

7800 Models

Congratulations on your purchase of a Graco® stroller!

Graco is a world leader in strollers and has helped thousands of parents transport their children in comfort. We believe your new Graco® stroller is a wise choice, promising many hours of enjoyment for your baby.

Before using your stroller, please take a few minutes to read this Owner's Manual. The short time you spend reading these instructions will help you assemble and use your stroller properly.

Please save your Owner's Manual for future use.

Customer Satisfaction

Our goal is to make every product the best it can be! We are also committed to supporting our products after purchase. If you would like to speak to Graco about your product, please contact our **Customer Service Department at 1-800-345-4109**. Our knowledgeable staff will be ready to answer any questions you may have concerning parts, use or maintenance. When you call, please have the **model and serial numbers** ready so your call may be processed quickly and efficiently.

⚠ WARNING



Never leave child unattended.
Always keep your child in view.



Use of the stroller with a child weighing more than 40 lbs. (18.1 kg) will cause excessive wear and stress on the stroller. Use the stroller with only one child at a time.

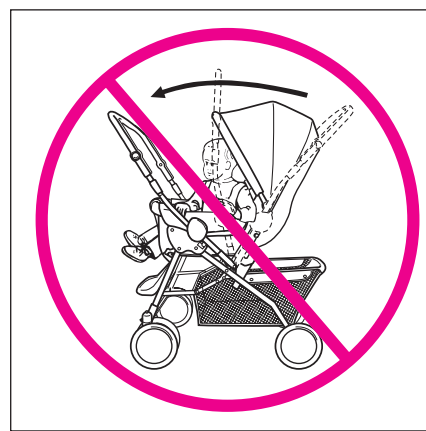

Use care when reversing handle to avoid catching child's arms or hands in the mechanism. When making adjustments to your stroller, always be sure that all parts of your child's body are clear of any moving parts.

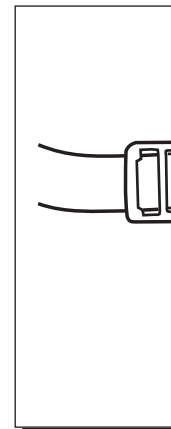

Avoid serious sliding out. A



DO NOT place bags, parcels on handle or on the child of the stroller.

TO PREVENT (4.5 kg) in the

DO NOT ALL cause injury.

NEVER ALL

STROLLER while jogging

AVOID STRA neck, suspen

DISCONTIN

THIS PRODU

F
s
i

Failure to follow these warnings and the assembly instructions could result in serious injury or death.

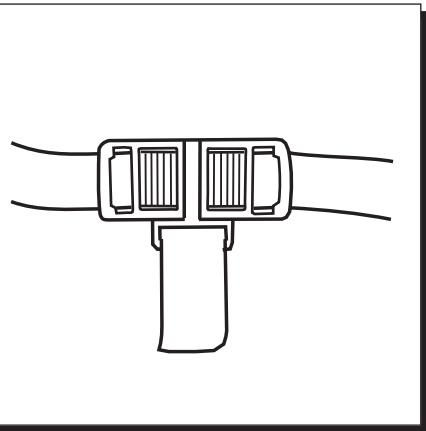

Avoid serious injury from falling or sliding out. Always use seat belt.

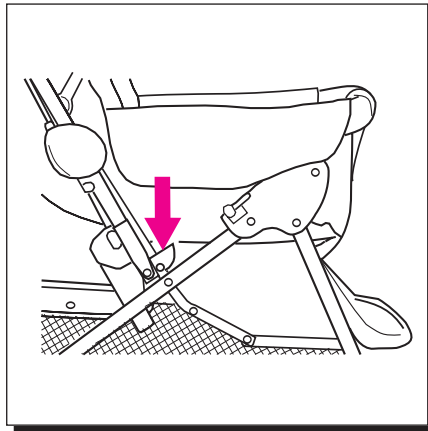

Be certain the stroller is fully erected and latched before allowing your child near the stroller.



Never place child in the stroller with head toward front of the stroller.



DO NOT place purses, shopping bags, parcels and accessory items on handle or canopy. They may fall on the child or change the balance of the stroller and make it unstable.

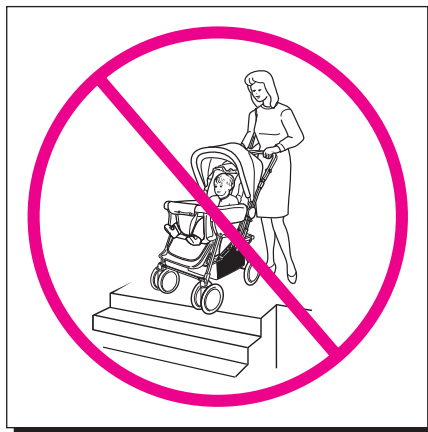

Never use stroller on stairs or escalators. You may suddenly lose control of the stroller or your child may fall out. Also, use extra care when going up or down a step or curb.

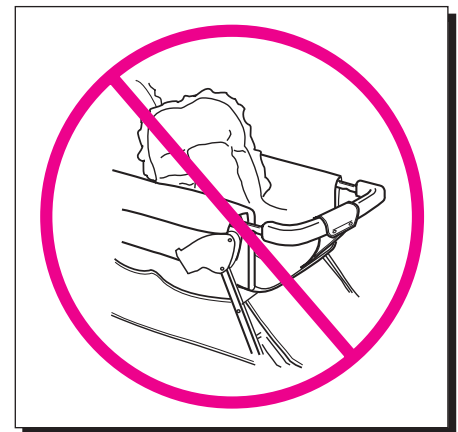

STRANGULATION HAZARD: Never use your stroller with the arm bar extended without the boot properly attached.

TO PREVENT A HAZARDOUS CONDITION, do not place more than 10 lbs. (4.5 kg) in the storage basket.

DO NOT ALLOW YOUR CHILD to stand on the basket. It may collapse and cause injury.

NEVER ALLOW YOUR STROLLER to be used as a toy.

STROLLER TO BE USED only at walking speed. Product not intended for use while jogging, skating, etc.

AVOID STRANGULATION. DO NOT place items with a string around your child's neck, suspend strings from this product, or attach strings to toys.

DISCONTINUE USING YOUR STROLLER should it become damaged or broken.

THIS PRODUCT IS NOT INTENDED FOR COMMERCIAL USE.

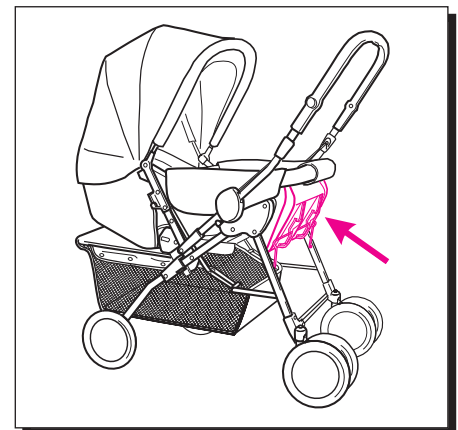

Child may slip into leg openings and strangle. Never use in reclined carriage position unless footrest is placed under padded front bar and wire snapped into lower notch.

FOR ADDITIONAL IMPORTANT INFORMATION, please see the Helpful Hints and Care and Maintenance sections in these instructions.

PARTS LIST

CHECK that you have all the parts listed below BEFORE assembling your stroller. If any parts are missing, call Customer Service at 1-800-345-4109.

THIS PRODUCT REQUIRES ADULT ASSEMBLY.
No tools required for assembly.

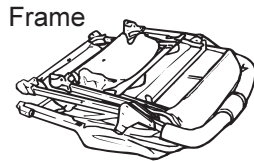
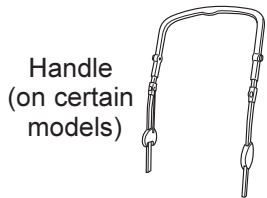

Rear axle

OR

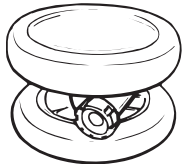
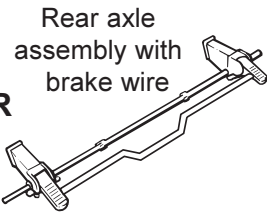

Front wheel assembly (2)



Rear wheel (2)



Cap (2, 1 extra)



Retainer (2, 1 extra)



Swivel lock button (2)

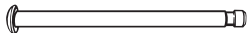

Pin (2)



Hub cap (2)
(on certain models)

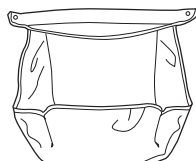

Boot

To Unpack Stroller

Step 1.

Flatten stroller carton to protect floor.

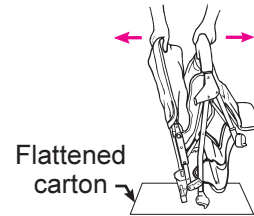

Step 2.

Open stroller on carton as shown until latched.

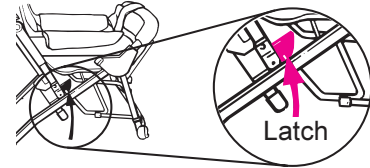

To Install Handle (on certain models)

Step 1.

Turn handle brackets straight up.

Handle bent towards rear

Step 2.

Position handle as shown.

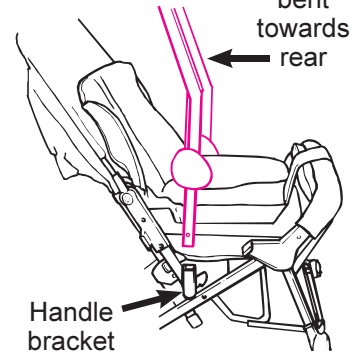

Step 3.

Place both sides of handle into brackets and push down until latched.

Handle bracket

NOTE: Be sure buttons are securely latched in bracket holes. Check by pulling firmly up on handle.

To Assemble Rear Axle

Your stroller will have either a rear axle or a rear axle assembly with brake wire. Follow the appropriate instructions below.

Rear axle:

Step 1.

Turn stroller over as shown.

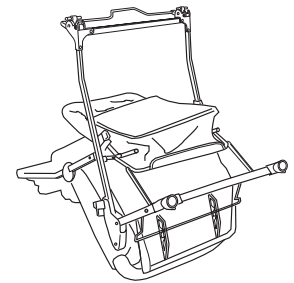

Step 2.

Slide the rear axle through the holes in both axle brackets.

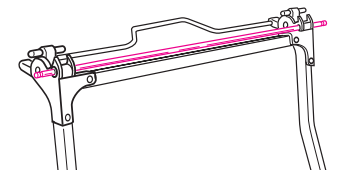

Rear axle assembly with brake wire:

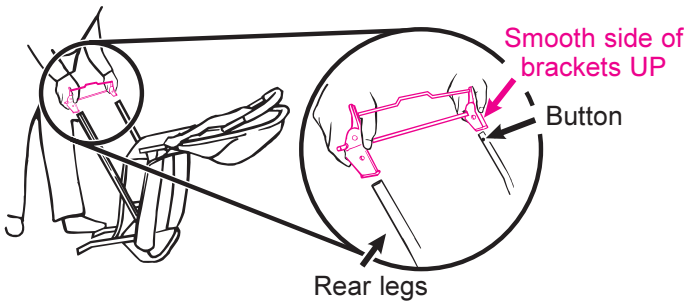

Step 1.

Turn stroller over as pictured above.

Step 2.

Position rear axle assembly as shown.

Step 3.

Start sliding both brackets onto leg tubes at the same time.

Step 4.

Push both brackets all the way on until metal buttons snap into bracket holes on inside of legs.

Step 5.

Pull firmly on each bracket to be sure buttons are snapped into bracket holes.

To Assemble Rear Wheels

Place one rear wheel, red retainer, and white cap on one end of rear axle **in order** as shown below. Push red retainer onto axle **BEFORE** attaching white cap. Repeat on other side.

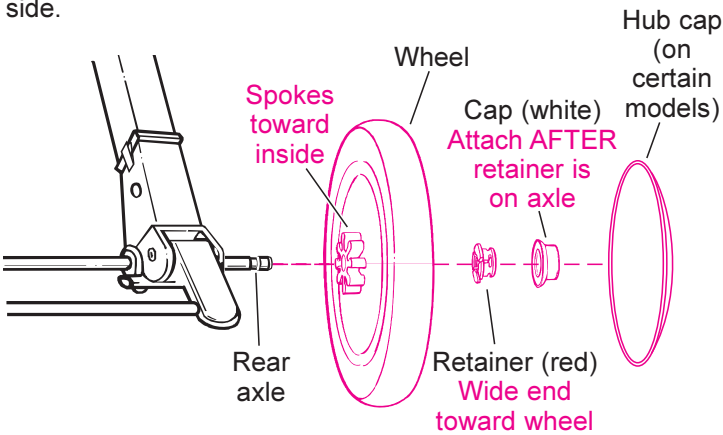

Snap red retainer into axle groove. Then snap cap over red retainer as shown. **Be sure cap is snapped securely over red retainer.**

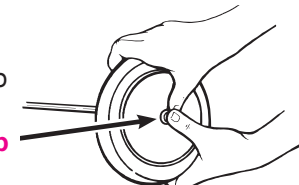

To Assemble Front Wheels

Step 1.

Snap swivel lock button onto wheel mount as shown. This must be done **BEFORE** pin is inserted (next step).

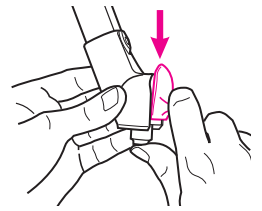

Step 2.

Insert pin through hole in wheel mount. Then push **round** end of a front wheel assembly up onto pin as shown until it snaps into place.

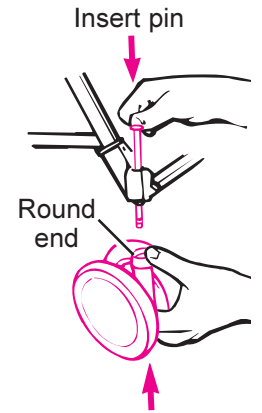

NOTE: Check wheel attachment by pulling down on the front wheel assembly.

Step 3.

Repeat above steps for the other side.

Push wheels up

To Unfold Stroller

Step 1.

Unfold footrest from under armrest.

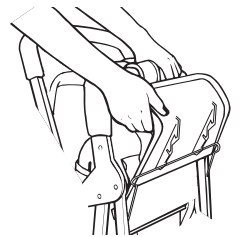

Step 2.

Release storage latch.

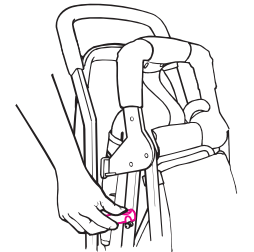

Step 3.

Unfold as shown.

▲WARNING Be certain the stroller is fully erected and latched before allowing your child near the stroller.

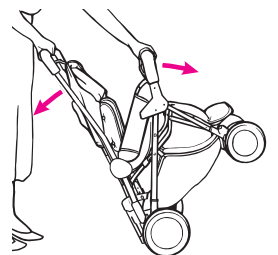

To Use Brakes

▲WARNING Always apply brakes to park stroller.

Push **DOWN** on center of wire to park.

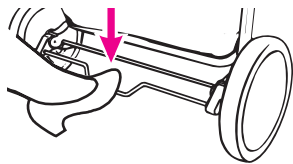

Lift **UP** to stroll.

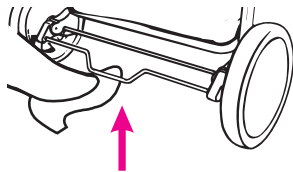

To Change to Swivel or Non-swivel Wheels

Front swivel wheels lock for use on uneven surfaces such as grass, stones or gravel.

Before locking swivels, push stroller forward a few feet to ensure that the wheels are correctly positioned.



Push buttons up or down, depending on model, to lock or release swivels. Turn swivel to check that it is locked or released.

To Use Basket

To lower basket, push **DOWN** on basket.

To raise basket, lift **UP** on basket.

▲WARNING Do not allow your child to stand on the basket. It may collapse and cause injury.

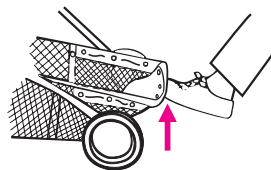
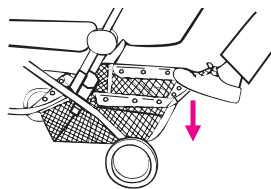

To Adjust Handle Height

Push both buttons and slide handle to one of the four possible positions.

Be sure handle is engaged in one of the latching positions.

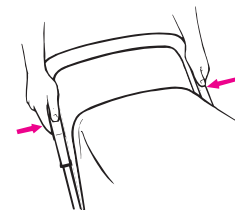

To Move Handle to Carriage Position

Step 1.

Pull up on both plastic slides on the handle as shown to unlock.



Step 2.

Move handle to new position.

NOTE: Remember to reverse the swivel wheels when reversing the handle.

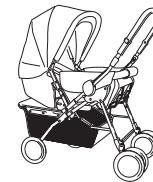

▲WARNING Use care when reversing handle to avoid catching child's arms or hands in the folding mechanism.

To Use Canopy

To open canopy, pull it forward.

Canopy bag (on certain models) carries a maximum of 2 pounds (0.9 kg).

On certain models, you can unzip the rear panel and fold it out of the way to see your baby.

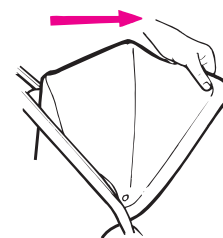

To Use Head Supports

To use stroller with a smaller child, pull the plastic pieces from pockets located in the back of the cloth seat pad, and reinsert them with curved side toward the front.

To use stroller with a larger child who does not need head support, insert the plastic pieces with the curved side toward the back.



Back of cloth seat pad

To Adjust Back

Step 1.

Push back of seat slightly forward while squeezing as shown to unlock.

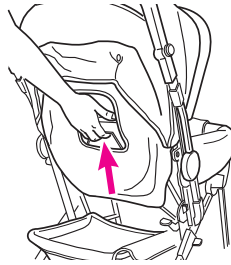

Step 2.

Adjust to desired position.

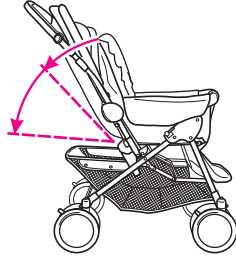

To Raise Footrest

Lift footrest to desired position and hook wire into footrest bracket.

▲ WARNING Child may slip into leg openings and strangle. Never use in a reclined carriage position unless footrest is placed under padded front bar and wire is snapped into lower notch.

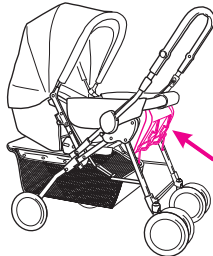
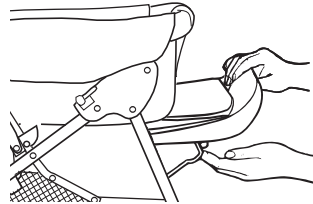

To Adjust or Remove Arm Bar (on certain models)

Step 1.

Feel through fabric at sides for buttons. Push in buttons to move the arm bar to extended position or remove it.

After extending arm bar or returning it to original position, pull on bar to be sure both sides are attached.

Buttons under fabric

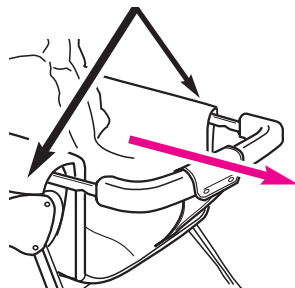

Step 2.

To replace the arm bar after removing it, push arm bar into armrest holes until it locks in place. Pull on bar to be sure both sides are attached.

To Attach Boot

The method of boot attachment depends on whether or not your stroller has an adjustable front arm bar. Follow the appropriate instructions below.

Non-adjustable arm bar:

Step 1.

Raise footrest and place boot under footrest. Slide boot over the front of stroller.

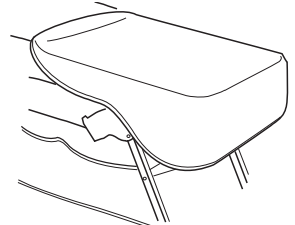

Step 2.

Snap straps at top of boot around stroller frame on both sides as shown.

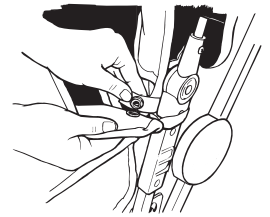

Adjustable arm bar:

Step 1.

Move the arm bar to extended position. Pull on bar to be sure both sides are attached.

Step 2.

Raise footrest and place boot under footrest. Slide boot over front of stroller. **IMPORTANT:** Snap straps at bottom of boot around front legs on both sides as shown.

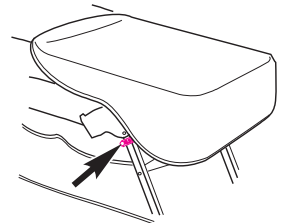

Step 3.

Snap straps at top of boot around stroller frame on both sides as shown.

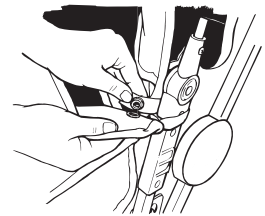

▲ WARNING STRANGULATION HAZARD. Never use your stroller with arm bar extended without the boot properly attached.

To Secure Your Child

▲WARNING Avoid serious injury from falling or sliding out. Always use seat belt.

Step 1.

Place crotch strap between child's legs. Snap both side buckles to the center buckle. Adjust belt as needed to get a snug fit around your child.

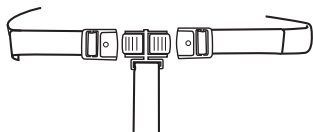

Step 2.

Push in on front of buckle to release.

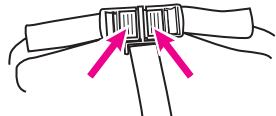

To Wash Seat With Removable Boards (on certain models)

Remove the cloth seat pad from the stroller and unsnap the seat from the stroller frame.

Remove the four boards from the pockets on the underside of the seat by pulling the boards out from under the flaps.

The seat may be machine washed in lukewarm water on delicate cycle and drip-dried. **NO BLEACH.**

When the seat is completely dry, place the boards back in the pockets and **tuck the boards under the flaps** so they will be held securely in the pockets.

Snap the seat to the frame and replace the seat pad.

▲WARNING Entrapment or suffocation hazard: **DO NOT** use the seat without the boards.

To Fold Stroller

Before folding, (1) adjust back to upright position; (2) adjust handle to rear position; (3) fold canopy; (4) remove boot if installed.

HINT: Lower the collapsible basket first to provide easier access to the folding latch.

Step 1.

Push on latch to fold as shown.

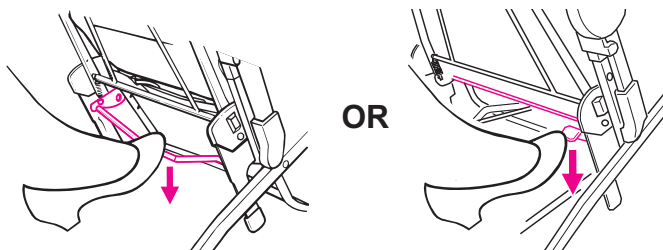

Step 2.

Push handle forward.



Step 3.

Release secondary latch (on certain models) as shown.

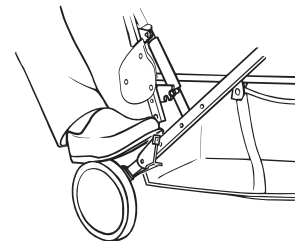

Step 4.

Lock storage latch.

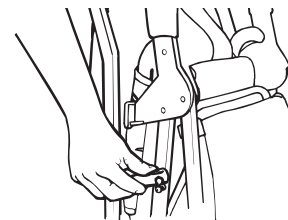

HELPFUL HINTS

IF WHEEL SQUEAKS, use a light oil (e.g., WD-40, 3-in-1, or sewing machine oil). It is important to get the oil into the axle and wheel assembly as shown.

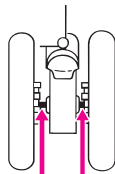

WHEN USING YOUR STROLLER OVER UNEVEN SURFACES (such as grass, stones, and gravel), lock front swivel wheels.

BEFORE LOCKING FRONT SWIVELS, it is important to first push the stroller forward a few feet to ensure that the wheels are correctly positioned.

WHEN USING YOUR STROLLER AT THE BEACH, completely clean your stroller afterward to remove sand and salt from mechanisms and wheel assemblies.

CARE AND MAINTENANCE

DO NOT MACHINE WASH SEAT (with permanent inner boards). It should only be wiped with a mild detergent, taking care not to soak the material. Seat with removable inner boards (on certain models) may be machine washed in lukewarm water on delicate cycle and drip-dried. **NO BLEACH.**

REMOVABLE PAD may be machine washed in lukewarm water on delicate cycle and drip-dried. **NO BLEACH.**

FROM TIME TO TIME CHECK YOUR STROLLER for loose screws, worn parts, torn material or stitching. Replace or repair the parts as needed. Use only Graco® replacement parts.

TO CLEAN STROLLER FRAME, use only household soap or detergent and warm water. **NO BLEACH.**

EXCESSIVE EXPOSURE TO SUN OR HEAT could cause fading or warping of parts.

Replacement Parts

Instructions for ordering stroller parts:

Complete form below. Your stroller model number **MUST** be included on the form to ensure proper replacement parts. Your model number can be found on a sticker on the rear leg of your stroller. **Payment must accompany your order.**

Parts List:	Price:**
Removable seat pad	\$ 22.00
Front wheel assembly	\$ 15.00 (each)
Rear axle	\$ 7.00
Rear axle assembly with wire	\$ 15.00
Rear wheel	\$ 7.00 (each)
Adjustable arm bar*	\$ 15.00
Basket	\$ 12.00
Boot (for adjustable arm bar)	\$ 15.00
Boot (for non-adjustable arm bar)	\$ 12.00
Canopy	\$ 17.00
Handle	\$ 25.00
Seat with permanent boards*	\$ 30.00
Seat with removable boards*	\$ 30.00

* On certain models only.

** Prices subject to change without notice.

IF YOU NEED HELP

If you have any questions, please call toll-free:

1-800-345-4109

Return the form below with payment to:
GRACO CHILDREN'S PRODUCTS INC.
CUSTOMER SERVICE DEPARTMENT
MAIN STREET
ELVERSON, PA 19520

Model Number	SHIP TO:
(Must be filled in)	Name _____
<input type="checkbox"/> Removable seat pad	Address _____
<input type="checkbox"/> Front wheel assembly	City, State, Zip _____
<input type="checkbox"/> Rear axle	() _____
<input type="checkbox"/> Rear axle assembly	Telephone _____
<input type="checkbox"/> Rear wheel	<input type="checkbox"/> Check enclosed
<input type="checkbox"/> Adjustable arm bar	(payable to Graco Children's Products Inc.)
<input type="checkbox"/> Basket	<input type="checkbox"/> Charge to credit card:
<input type="checkbox"/> Boot (adjustable arm bar)	<input type="checkbox"/> Visa
<input type="checkbox"/> Boot (non-adjustable arm bar)	<input type="checkbox"/> MasterCard
<input type="checkbox"/> Canopy	<input type="checkbox"/> Discover
<input type="checkbox"/> Handle	
<input type="checkbox"/> Seat with permanent boards	
<input type="checkbox"/> Seat with removable boards	
Total: _____	Account #: _____
6% sales tax (PA only): _____	Expiration date: _____
Total amount due: _____	Signature: _____